

# Linear Coherent Optical Receivers

Leif A. Johansson, Uppili Krishnamachari, Anand Ramaswamy, Jonathan Klamkin,  
Sasa Ristic, H.-F. Chou, Larry A. Coldren, Mark Rodwell, John E. Bowers

*Electrical and Computer Engineering Department, University of California, Santa Barbara, CA 93106  
Email: leif@ece.ucsb.edu*

**Abstract:** The development of linear coherent receivers at UCSB is reviewed. The progression of the feedback receiver architecture toward closer integration, lower feedback delay and higher performance is outlined. The alternative XOR receiver approach is summarized.

©2010 Optical Society of America

**OCIS codes:** (250.3140) Integrated optoelectronic circuits, (060.1660), Coherent communications (060.5060), Phase modulation, (060.2360) Fiber optics links and subsystems.

## 1. Introduction

Fiber optic links are attractive for remoting exposed antenna systems. In contrast to coaxial cables, they are EMI immune, lightweight and have low losses at high RF modulation frequencies. Further, if a robust optical modulator is used, the optical link can function as a buffer at the antenna unit, protecting sensitive receiver front-end electronics from large RF power surges. The traditional challenge for RF photonic links has been component limitations resulting in optical links with high noise figure and low dynamic range.

Traditionally optical intensity modulation (IM) has been considered for RF photonic links. An early result, 1994, demonstrated an optical link with 132 dB SFDR in 1 Hz bandwidth, using a carefully optimized optical modulator [1]. This result is still representative to the performance of state-of-art IM RF photonic links today, more than 15 years later. The cause of the slow advance of analog link performance is related to the modulation format. Optical intensity modulators are limited to operation between zero and full transmission. To avoid clipping, the linear RMS modulation depth is typically limited to <10% of full modulator swing. To reach higher dynamic range, the optical power must therefore be increased, but that also increases shot noise, leading only to a weak improvement in SFDR at the expense of a strong increase in detector power.

More recently, optical phase modulation has been considered for linear optical links [2,3]. Linear optical phase modulators are available, notably LiNbO<sub>3</sub> modulators which rely on the linear electro-optic effect. Further, optical phase modulators do not have any hard-limits to available modulation depth, high modulation depth can be reached through increased spectral envelope in the optical domain from modulation sidebands, as determined by the Bessel functions. Common interferometric approaches to convert optical phase modulation to intensity modulation typically have a non-linear sinusoidal response.

This paper reports on current efforts to develop coherent optical receivers for linear optical phase demodulated signals with a high modulation index. Two alternative approaches have been considered, first; a phase-feedback coherent receiver architecture, and second; optical heterodyne detection with linear RF phase detection.

## 2. Feedback Receiver Approach

The feedback receiver architecture is illustrated in Figure 1, left. The received optical signal is mixed with the optical LO similar to a conventional receiver. The detected differential photocurrent is then amplified and fed back into a tracking phase-modulator to form a feedback loop. For high feedback gain and using a linear tracking modulator, the drive signal to the tracking modulator is linearly related to the received optical phase. An alternative illustration of increased linearity is that with higher feedback gain and closer tracking, the received signal-LO phase difference gets smaller, allowing the interferometer to operate within its linear range. Figure 1, center illustrates this, where the predicted output from the balanced receiver compares well with measured data for increasing loop transmission gain, using a slow proof-of-concept bench-top demonstrator built from optical fiber and a LiNbO<sub>3</sub> tracking modulator [3]. Figure 1, right shows the corresponding SFDR. 124.3 dBHz<sup>2/3</sup> is measured for only 3mA of received photocurrent, corresponding to a respectable 131.5 dBHz<sup>2/3</sup> in the shot-noise limited extrapolation [3]. This initial demonstration illustrated the potential high performance of the approach is high-performance components are used.

One limitation of a fiber based, discrete-component demonstrator is that the latency in the feedback loop limits the unity-gain bandwidth. As an engineering rule, the bandwidth is limited to  $\sim 1/(10 \times \text{loop delay})$ . For this reason, the linearity data had to taken at around 150 kHz to ensure sufficiently high loop gain for linear operation.

## OThF5.pdf

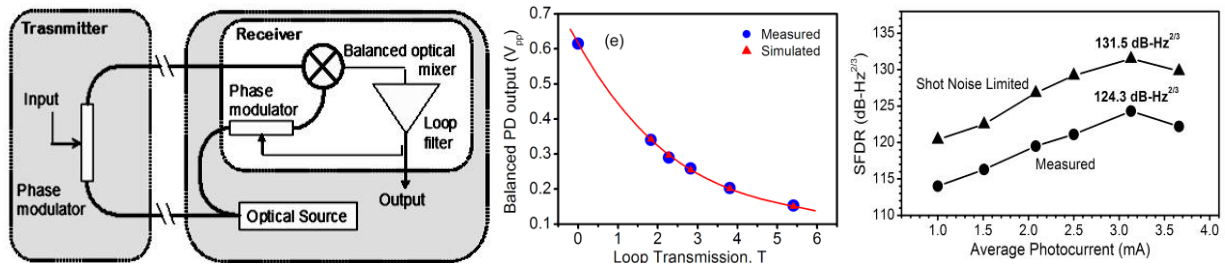

Figure 1. Left: Schematic of feedback coherent receiver approach. Center: Relation between loop transmission gain and suppression of detected differential phase. Right: Measured SFDR using discrete component proof-of-concept demonstrator.

*Generation I integrated receiver:* To reach higher operating frequencies, the loop latency must be reduced. Figure 2, left shows an SEM of the generation I integrated receiver IC, containing a high power balanced uni-traveling-carrier photodiode (UTC-PD), a 2x2 multimode interference (MMI) coupler, shown in Figure 2, center, and multi-quantum well tracking phase modulators [4]. This PIC is wirebonded to an electronic integrated circuit (EIC) that provides transconductance amplification of the feedback signal to drive the phase modulator to close the feed-back loop.

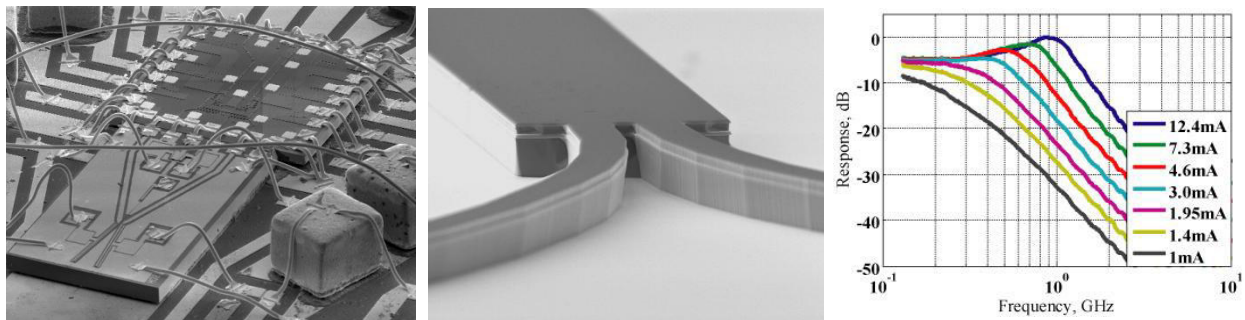

Figure 2. Left: SEM of Integrated O/E Receiver showing generation I photonic and electronic IC. Center: detail of generation I photonic IC, showing the 2x2 MMI coupler. Right: Resulting link gain at different detected photocurrent levels

The PM link response using the closed-loop receiver is shown in Figure 2, right. At high frequency, or at low photocurrents, the link gain is proportional to the photocurrent and the voltage drop over the capacitive detector load. For higher photocurrents and at lower frequencies, the loop gain is significant, and the link gain becomes proportional to the ratio of remote modulator V- $\pi$  and the V- $\pi$  of the tracking modulator. The corresponding link SFDR is as high as 125 $\text{dBHz}^{2/3}$  at 300MHz frequency [5]. For this receiver, the estimated loop delay was estimated to be  $\sim 35\text{ns}$ , sufficient to support  $\sim 3\text{GHz}$  loop bandwidth. The measured bandwidth was  $>1\text{GHz}$ .

*Generation II integrated receiver:* To reach further improved loop bandwidth and gain, the delay must be reduced even further. This can be achieved by replacing the MMI coupler with its attributed curved input waveguides with a compact trench coupler, as shown by Figure 3, left. This coupler can be as compact as a few tens of microns in total, while allowing close integration with detectors and modulators, as shown by the fabricated device in Figure 3, center, showing input waveguides with tracking phase modulators, the 2x2 slot coupler, and a balanced UTC detector pair. Further reduction of the loop delay can be reached by a more compact integration of photonics and feed-back electronics by replacing wire-bonds and RF lines on the photonic IC by direct flip-chip bonding between photonics and electronics, as shown by Figure 3, right. It is expected that this will lead to a loop delay  $<10\text{ps}$  and lower insertion losses, with a corresponding improvement in receiver performance.

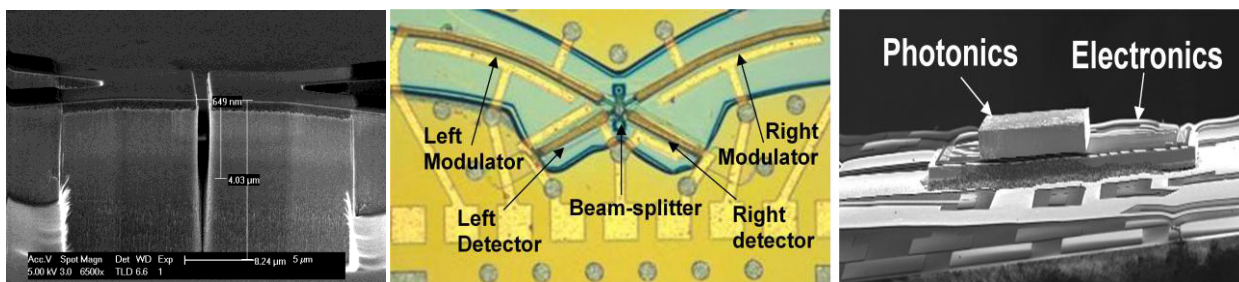

Figure 3. Left: Detail of compact optical trench coupler. Center: Generation II photonic IC incorporating detectors, coupler and modulators. Right: Generation II photonic IC flip-chip bonded on to feedback electronic IC.

### 3. Linear XOR Receiver

One limitation of the feedback receiver approach is that the bandwidth is delay restricted and given available integration technology, the high-gain low distortion operating frequency will remain a few GHz. To address operating frequencies up to 20 GHz, an alternative approach has been investigated based on a linear RF phase detector. Figure 4, right shows a schematic of the linear XOR optical receiver. Here, the received optical signal is downconverted to an RF signal, transferring the optical phase modulation to the RF domain. Now, a wider tool-box for linear RF phase detection can be utilized. In this approach, the RF signal is limited to form a square-wave. The phase information is now contained only in the timing of zero-crossings. The limited signal is compared to a clock-reference in an XOR-gate and the output is then low-pass filtered to remove the RF carrier. This receiver has a linear response over a  $\pm\pi/2$  range. By inserting an  $N$ -times digital frequency divider before the clock, phase modulation becomes linear over a  $\pm N\times\pi/2$  range. Figure 4, left shows two-tone experimental results at 0.5 GHz signal frequency and 4 GHz RF carrier, using the proposed phase demodulator [6]. It is observed that the XOR generated intermodulation products suppressed by 20 dB compared to a standard sinusoidal phase detector. Further, it is observed that implementing the frequency division, two-tone modulation depth exceeding  $\pi$  rad p-p phase swing is possible without resulting in clipping.

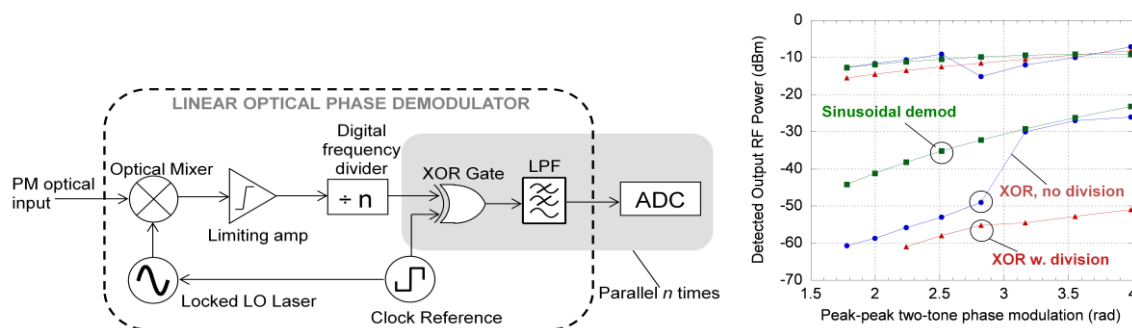

Figure 4. Left: Schematic of the linear XOR receiver architecture. Right: Resulting intermodulation performance with and without digital frequency division, and compared to conventional sinusoidal demodulation.

One advantage of the XOR receiver is that the output signal frequency is scaled down by the frequency division factor,  $N$ . With sufficient division, high performance, lower sampling rate ADCs can be used to digitize broad-band high-frequency received RF signals. The different Nyquist bands are separated by implementing a factor-of- $N$  frequency divider with  $N$  outputs such that each zero transition is captured. Using the digitized data, the full broadband RF signal can then be fully reconstructed.

### 4. Conclusions

In this paper, the development of linear integrated coherent receivers at UCSB is reviewed. The first approach relies on a closed-loop feedback architecture to a closely integrated tracking modulator. The progression toward closer integration, lower feedback delay and higher performance has been outlined. The second approach relies on heterodyne detection, frequency division and linear RF phase detection. Results from a proof-of-concept demonstration are shown.

### 5. Acknowledgement

The authors acknowledge Northrop Grumman Space Technology for providing the EIC. This work was supported by the DARPA PHOR-FRONT program under USAF contract FA8750-05-C-0265.

### 6. References

- [1] G. Betts, IEEE Trans. Microwave Theory Tech. , vol. 42, pp. 2642-2649, Dec. 1994.
- [2] T.R. Clark and M.L. Dennis, IEEE Photonics Technology Letters, Vol. 19, Issue 16, pp. 1206-1208, Aug. 15, 2007.
- [3] H.F. Chou, *et al.*, IEEE Photonics Technology Letters, vol 19, No.12, pp. 940-942, JUNE 2007.
- [4] J. Klamkin, *et al.*, Optical Fiber Communication (OFC), paper no. OMK4, San Diego, CA, MARCH 2009.
- [5] A. Ramaswamy, *et al.*, Journal of Lightwave Technology, vol. 26, no. 1, pp. 209-216, JANUARY 2008.
- [6] L. A. Johansson, *et al.*, 2009 IEEE MTT-S International Microwave Symposium Digest, pp. 157-160, Boston, MA, JUNE 2009.