

# Coherent Receiver Based on a Broadband Optical Phase-Lock Loop

A. Ramaswamy\*, L.A. Johansson\*, J. Klamkin†, C. Sheldon\*, H.F. Chou††, M.J. Rodwell\*,  
L.A. Coldren\*† and J.E. Bowers\*

\* ECE Dept. University of California, Santa Barbara, CA 93106

† Materials Dept. University of California, Santa Barbara, CA 93106

†† LuminentOIC Inc., Chatsworth, CA 91311

anand@ece.ucsb.edu

**Abstract:** We propose and demonstrate a 1.45GHz bandwidth optical phase-lock loop receiver for linear optical phase demodulation. Using the receiver in a link application, a spurious free dynamic range of  $125 \text{ dBHz}^{2/3}$  is measured at 300MHz.

©2007 Optical Society of America

**OCIS codes:** (250.3140) Integrated optoelectronic circuits, (060.1660), Coherent communications (060.5060), Phase modulation, (060.2360) Fiber optics links and subsystems.

## 1. Introduction

Optical phase-locked loops have found renewed interest with the reemergence of coherent optical link technologies. For data transmission, a homodyne optical phase-lock loop can generate the highest sensitivity when sufficient loop bandwidth can be maintained [1]. This technique becomes particularly attractive at high bit-rates when alternative DSP-based solutions are not yet mature, or when low receiver power consumption is desirable. Alternative phase-lock loop applications are coherent synchronization of laser arrays [2] or frequency synthesis by offset locking [3].

In this work, a broadband optical phase-lock loop is demonstrated for demodulation of analog phase-modulated optical links. Phase modulation has attracted interest for application in linear optical links with the existence of very linear optical  $\text{LiNbO}_3$  phase modulation as an alternative to non-linear intensity modulators. The challenge is now transferred to the receiver side. In a standard optical interferometer based phase demodulation, there is a sinusoidal relation between the optical phase and the detected photocurrent. This nonlinearity limits the available link dynamic range. In contrast, a high-gain optical phase-lock loop will provide linear demodulation provided phase feedback is supplied to a linear optical phase modulator.

Figure 1 shows a schematic of the receiver architecture, previously demonstrated in a low-frequency proof-of-principle experiment [4]. Here, a common source is split in two paths, each containing an optical phase modulator. The input signal is applied to the first modulator. Upon recombination with the second part, the detected optical signal has a sinusoidal dependence on the optical phase. The photocurrent is then measured, amplified and provided as negative feedback to the second reference modulator. The detected net phase is now reduced by a factor  $1/(1+T)$  where  $T$  is the loop roundtrip phase gain, such that the interferometer is now operating within its linear range. It should be noted that the feedback cannot separate detector shot-noise from signal so that the shot-noise limited SNR remains unchanged despite the reduction in net received phase.

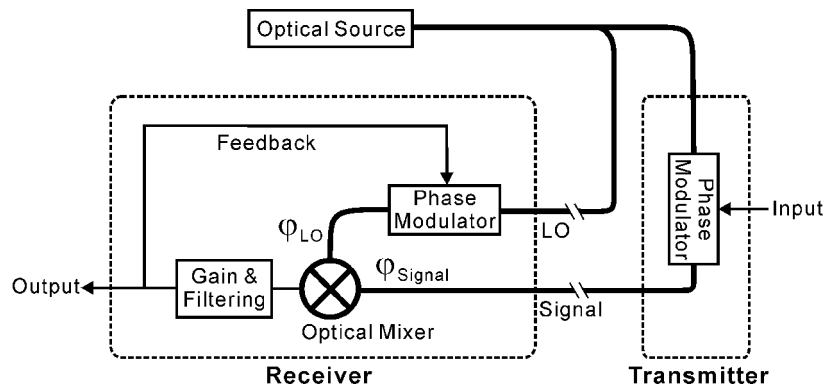

Fig. 1. Concept schematic of the demonstrated coherent receiver with feedback. Thick lines: optical link; thin lines: electrical link.

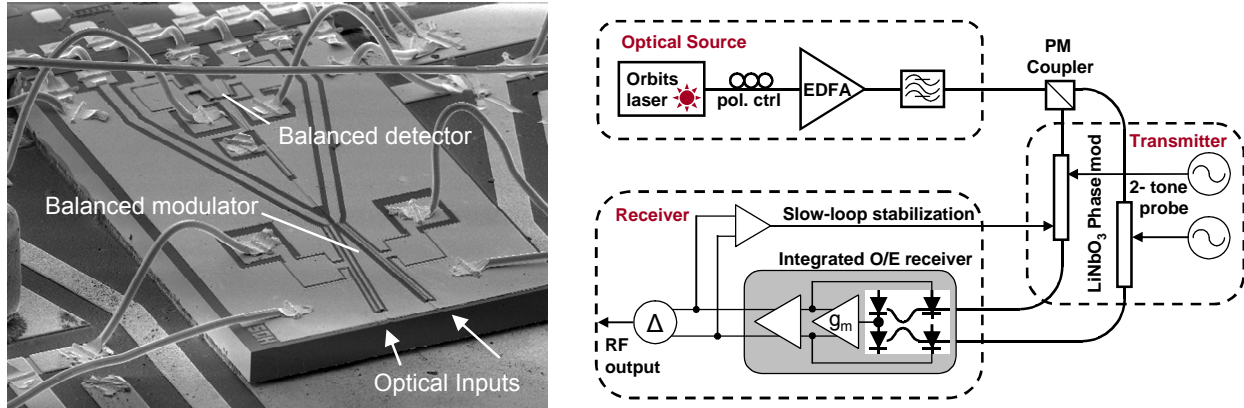

Fig.2. a) SEM of Integrated O/E Receiver b) Schematic of Experimental Setup

## 2. Integrated Receiver

The optical phase demodulator consists of two integrated chips – one photonic, one electronic – mounted on a common microwave carrier. Figure 2a) shows the photonic integrated circuit consisting of a balanced UTC photodetector [5], tracking phase modulators and a 2x2 waveguide MMI coupler. The wirebonds connecting to the hybrid integrated electronic IC (not shown) can be seen in the upper part of the figure. In quadrature, this type of balanced receiver discriminates against common-mode and second-order nonlinearities. The tracking optical phase modulators are driven differentially so as to add opposite-sign phase shifts to the incoming signal and LO resulting in a cancellation of even-order nonlinearities and common-mode noise. Additionally, driving the modulators in a differential fashion doubles the drive voltage presented to the modulator thereby reducing the maximum voltage required. The capacitances of the photodiodes and modulators are exploited as circuit elements rather than being parasitics that need to be eliminated. They perform the desired loop integrations and hence, can be much larger. The electronic chip that interfaces with the PIC is primarily a trans-conductance amplifier that converts the voltage generated by photodiode integration into a modulator drive current. The modulator integrates this current to produce the required phase shift. It also has a pair of buffer amplifier capable of driving 50 ohms. The electronic chip improves the phase margin and thereby provides stability to the system.

## 3. Analog Link Experiment

A schematic of the experimental setup is shown in Figure 2 a). The CW optical source consists of an Orbits low noise, high power, frequency stabilized laser at 1537.40nm. The output of the laser is amplified using a high power EDFA. The polarization controller prior to the EDFA is used to adjust the splitting ratio of the power in the two branches emerging from the PM Coupler. After the coupler, polarization maintaining fibers and components are used for managing polarization and maintaining stability.

To ensure no mixing products are generated in the two-tone drive signal, separate LiNbO<sub>3</sub> phase modulators were used to combine the two closely spaced RF tones ( $\Delta f=2\text{MHz}$ ) in the optical domain. The phase modulators have  $V_{\pi}$ 's of 4.4V and 5.5V respectively. At the output of the receiver the differential signal is tapped into a slow feedback loop which generates a low frequency drive signal to one of the phase modulators as seen in Figure 2 b). This stabilizes the system against environmental drifts and maintains the bias of the phase demodulator at quadrature. The RF outputs are 180° out of phase and are differentially combined.

Due to the feedback architecture of the system, the effective swing across the phase demodulator is suppressed by a factor of  $1/(1+T)$  where  $T$  is the loop transmission gain. The frequency response of the device for varying values of photocurrent is shown in Figure 3 a). At high photocurrent and lower frequencies, the loop gain is sufficiently high such that the reference phase modulator is able to closely track the received signal phase. The optical link gain ( $G$ ) is here dependent on the ratio of drive voltage between source and reference modulator and is in this link -5dB. At high frequencies or at low photocurrent values, the loop transmission gain is low and hence, the link gain is proportional to the photocurrent and the loop filter transfer function as expected. The loop bandwidth, here defined by the 3-dB point, approximately where the loop transmission  $|T|$  crosses unity, reaches 1.45 GHz at 12 mA. The delay-limited bandwidth, within where the loop remains stable, is on the order of 4 GHz.

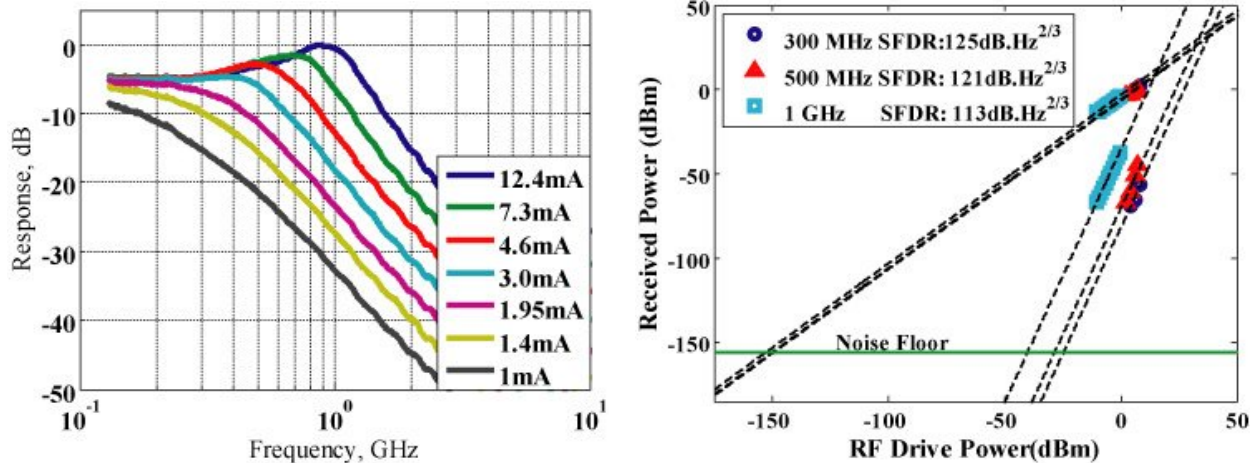

Fig. 3. a) Link gain at different detected photocurrent levels b) SFDR at 300 MHz, 500 MHz and 1 GHz

Figure 3 b) shows SFDR data taken at three different frequencies with 12mA of photocurrent in each detector. Due to the imperfect optical source used, the spontaneous emission noise from the EDFA has been removed from the noise level to reflect shot-noise limited receiver performance. With detector balance and a low-RIN source, this should be readily available. It was verified that the receiver noise was well below the calculated shot noise level. An SFDR of  $125\text{dB}\cdot\text{Hz}^{2/3}$  was measured at 300 MHz. At higher frequencies with reduced feedback, the SFDR degrades as can be seen in Figure 3b) to the point where there is no reduction in the net received phase (1 GHz). At 12 mA, the shot noise limited SFDR can be calculated at  $116\text{ dB}\cdot\text{Hz}^{2/3}$ .

#### 4. Summary

In this paper we have described and experimentally demonstrated a novel coherent integrated receiver based on a broadband optical phase locked loop. At 12mA of average photocurrent per photodiode the loop bandwidth is 1.45 GHz and the shot noise limited SFDR is  $125\text{dB}\cdot\text{Hz}^{2/3}$  at 300 MHz. Going to higher photocurrent values will increase the feedback effect, resulting in an enhanced dynamic range and high linearity over a wide band. The integration of the photonics and electronics in this receiver allows for the feedback delay to be short enough to sustain large amounts of loop gain at high frequencies. Thus it is successful in reducing the distortion due to a normal phase demodulator without any penalty in SNR.

#### Acknowledgements

The authors would like to thank helpful discussions with Larry Lembo, Steve Pappert and Jim Hunter. Further acknowledgement should be provided to Northrop Grumman Space Technologies for providing the electronic IC. This work was supported by the DARPA PHOR-FRONT program under United States Air Force contract number FA8750-05-C-0265.

#### References

- [1] E. Ip, J.M. Kahn, "Carrier synchronization for 3- and 4-bit-per-symbol optical transmission," *Journal of Lightwave Technology*, vol. 23, Issue 12, pp. 4110 - 4124 Dec. 2005.
- [2] A. Yariv, "Dynamic analysis of the semiconductor laser as a current-controlled oscillator in the optical phased-lock loop: applications," *Optics letters*, 30(17), 2191-2193, 2005.
- [3] U. Gliese, N.T. Nielsen, M. Bruun, E.L. Christensen, K.E. Stubkjaer, S. Lindgren and B. Broberg, "A wideband heterodyne optical phase-locked loop for generation of 3-18 GHz microwave carriers", *IEEE Photon. Technol. Lett.*, vol. 4, pp. 936-938, 1992.
- [4] Hsu-Feng Chou, A. Ramaswamy, D. Zibar, L.A. Johansson, J.E. Bowers, M. Rodwell, and L.A. Coldren, "SFDR Improvement of a Coherent Receiver Using Feedback," OSA topical meeting of Coherent Optical Techniques and Applications (COTA), Whistler, BC, 2006.
- [5] J. Klamkin, L.A. Johansson, A. Ramaswamy, Hsu-Feng Chou, M.N. Sysak, J.W. Raring, N.Parthasarathy, S.P. DenBaars, J.E. Bowers, L.A. Coldren, "Monolithically Integrated Balanced Uni-Traveling-Carrier Photodiode with Tunable MMI Coupler for Microwave Photonic Circuits," *Conference on Optoelectronic and Microelectronic Materials and Devices (COMMAD)*, Perth, Australia. Dec. 2006.